

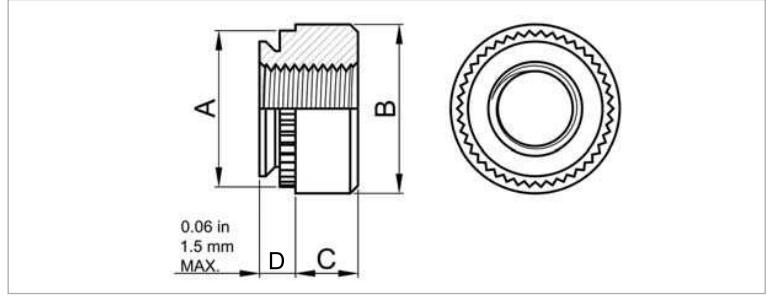

C & CS somunlar, ince metallerde güçlü bir tutunma sağlar. C&CS somunlar MIL-N-45938/1 özelliğine sahiptir.

C & CS nuts provide strong load-bearing threads in sheet metal and other thin section assemblies. C & CS nuts meet spec. features of MIL-N-45938/1.







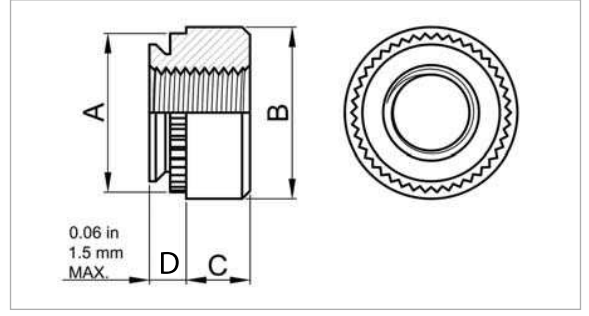

Series	Material	Finish
C	Işıl İşlemli Karbon Çeliği Heat-treated Carbon Steel	Çinko Zinc Clear
CS	300 Serisi Paslanmaz Çelik Series 300 Stainless Steel	ASTM A380 Pasivasyonlu Passivated ASTM A380

Boyutlar ve Özellikleri

Diş Ölçüsü Thread Size	Kod		D Max.	Min.	+ .08 mm - .000	A Nom.	B ± 0.25 mm	C ± 0.25 mm	Min
	Karbon Çelik Carbon Steel	Paslanmaz Çelik Stainless Steel							
M2 x 0,4	CM2-0	CSM2-0	0,76	0,8	4,25	4,22	6,3	1,5	4,8
	CM2-1	CSM2-1	0,97	1,0					
	CM2-2	CSM2-2	1,37	1,4					
	CM2-3	CSM2-3	2,21	2,3					
M2,5 x 0,45	CM2,5-0	CSM2,5-0	0,76	0,8	4,25	4,22	6,3	1,5	4,8
	CM2,5-1	CSM2,5-1	0,97	1,0					
	CM2,5-2	CSM2,5-2	1,37	1,4					
	CM2,5-3	CSM2,5-3	2,21	2,3					
M3 x 0,5	CM3-0	CSM3-0	0,76	0,8	4,25	4,22	6,3	1,5	4,8
	CM3-1	CSM3-1	0,97	1,0					
	CM3-2	CSM3-2	1,37	1,4					
	CM3-3	CSM3-3	2,21	2,3					
M3,5 x 0,6	CM3,5-0	CSM3,5-0	0,76	0,8	4,75	4,73	7,1	1,5	5,6
	CM3,5-1	CSM3,5-1	0,97	1,0					
	CM3,5-2	CSM3,5-2	1,37	1,4					
	CM3,5-3	CSM3,5-3	2,21	2,3					
M4 x 0,7	CM4-0	CSM4-0	0,76	0,8	5,4	5,38	7,9	2,0	6,9
	CM4-1	CSM4-1	0,97	1,0					
	CM4-2	CSM4-2	1,37	1,4					
	CM4-3	CSM4-3	2,21	2,3					
M5 x 0,8	CM5-0	CSM5-0	0,76	0,8	6,4	6,38	8,7	2,0	7,1
	CM5-1	CSM5-1	0,97	1,0					
	CM5-2	CSM5-2	1,37	1,4					
	CM5-3	CSM5-3	2,21	2,3					
M6 x 1,0	CM6-1	CSM6-1	1,37	1,4	8,75	8,72	11,05	4,08	8,6
	CM6-2	CSM6-2	2,21	2,3					
	CM6-3	CSM6-3	3,05	3,2					
M8 x 1,25	CM8-1	CSM8-1	1,37	1,4	10,5	10,44	12,65	5,47	9,7
	CM8-2	CSM8-2	2,21	2,3					
	CM8-3	CSM8-3	3,05	3,2					
M10 x 1,5	CM10-1	CSM10-1	2,21	2,3	14,0	13,94	17,35	7,48	13,5
	CM10-2	CSM10-2	3,05	3,2					
	CM10-3	CSM10-3	6,00	6,4					



Uygulama ve Güç Değerleri

Diş Ölçüsü  Thread Size	Segman Boşluğu Kodu Shan Code	Soğuk Çekme Çelik Cold-Rolled Steel			5052-H34 Alüminyum 5052-H34 Aluminium		
		Uygulama Gücü (kN)  Installation Force (kN)	Dışarı İtme (N)  Pushout (N)	Sökme Torku (N : m)  Torqueout (N:m)	Uygulama Gücü (kN)  Installation Force (kN)	Sökme Gücü (N)  Pushout (N)	Sökme Torku (N : m)  Torqueout (N:m)
M2 M2,5 M3	-0	11,2 - 15,6	465	2,1	6,7 - 8,9	275	0,9
	-1		545			390	1,1
	-2		1010			745	1,4
	-3		1100			850	1,4
M3,5	-0	13,4 - 26,7	475	1,8	11,2 - 13,4	290	1,8
	-1		565	1,8		465	1,9
	-2		1200	2,3		965	2,5
	-3		1300	2,5		1050	2,8
M4	-0	18 - 27	485	2,9	11 - 13,4	290	2,3
	-1		640	2,95		465	2,6
	-2		1245	4,2		965	4,0
	-3		1300	4,2		1100	4,0
M5	-0	18 - 31	525	3,6	11,2 - 15,6	290	3,0
	-1		790	3,6		475	3,6
	-2		1400	6,0		1180	4,7
	-3		1500	6,0		1225	5,7
M6	-0	27 - 36	1375	12,8	18 - 32	965	7,7
	-1-2-3		1755	16,4		1570	9,6
M8	-1	27 - 36	1860	18,1	18 - 32	1560	13,0
	-2						
	-3						
M10	-1	32 - 50	2000	36,2	22 - 36	1750	32,7
	-2						
	-3						

